



To All Lamborghini Dealers and Licensed Service Point .  
From Customer Service Department.  
Subject Seat Heater Electric Pin For RHD Vehicles.  
Group 9.81.00  
Date 12/10/2012  
Pages 7

**Subject**

Seat heater electric pin inversion for RHD vehicles.

**Model**

Lamborghini Aventador RHD version LP-700 My 2012 from Vin CLA00091 to CLA01058

**Warning:** some vehicles included in this VIN range may not be affected, so check carefully on the Lamborghini WEB Portal ( at the section named VIN Info) if the cars in your workshop or in your eventual stock are effectively affected before performing any other operation.

**Information to the field**

As a continuous product monitoring, Automobili Lamborghini Spa has found that on some **Right hand drive** vehicles the electric pins that command the driver seat heater has been swapped with the passenger seat, the related switch are inverted.

**Field solution**

Reinstall the pin in the correct way.

**Warranty Claim data**

The warranty reimbursement request for this rework action will be managed by the following standard Warranty Claim procedures.

---

*The information and procedures published below are strictly confidential and intended exclusively for authorized operators and individuals. All copyrights are the property of Automobili Lamborghini S.p.A based on copyright law. The company reserves the right to make updates and modifications. The reprinting, reproduction, forwarding to unauthorized people and/or to third parties and partial or entire translation thereof are prohibited without written authorization from Automobili Lamborghini S.p.A.*



**Campaign Code:** L834-A.08.12  
**Campaign Description:** Seat heater electric pin inversion  
**Cost Code:** 50  
**Component Code:** CCA0812  
**Trouble Code:** 220  
**Labour Code:** CCA0812100  
**Labour Time:** 0.8 h

Fill out the Service and Recall Campaign section in the warranty booklet, which is shown in the figure below.

Automobili Lamborghini S.p.A.			
Campagne service assistenza e campagne di richiamo / Service-und Rückrufaktion / Service and Recall Campaign Service et campagne de rappel / Campaña de Servicio y Llamada a Taller			
Service/Service Service/Service Servicio	<input type="checkbox"/>	Richiamo/Rückruf Recall/Rappel Llamada a Taller	<input type="checkbox"/>
Numero/Nummer Number/Numéro Número	<input type="text"/>		
Data/Datum/Date/Date/Fecha	<input type="text"/>		
Data riparazione/Reparaturdatum Repair Data/Date de réparation Fecha reparación	<input type="text"/>		
Eseguito dal Concessionario / Ausgeführt von der Vertragswerkstatt / Done by the Dealer Effectué par le concessionnaire / Efectuado por el Concessionario			
Firma / Unterschrift / Signature / Signature / Firma			
Service/Service Service/Service Servicio	<input type="checkbox"/>	Richiamo/Rückruf Recall/Rappel Llamada a Taller	<input type="checkbox"/>
Numero/Nummer Number/Numéro Número	<input type="text"/>		
Data/Datum/Date/Date/Fecha	<input type="text"/>		
Data riparazione/Reparaturdatum Repair Data/Date de réparation Fecha reparación	<input type="text"/>		
Eseguito dal Concessionario / Ausgeführt von der Vertragswerkstatt / Done by the Dealer Effectué par le concessionnaire / Efectuado por el Concessionario			
Firma / Unterschrift / Signature / Signature / Firma			



The information and procedures published below are strictly confidential and intended exclusively for authorized operators and individuals. All copyrights are the property of Automobili Lamborghini S.p.A based on copyright law. The company reserves the right to make updates and modifications. The reprinting, reproduction, forwarding to unauthorized people and/or to third parties and partial or entire translation thereof are prohibited without written authorization from Automobili Lamborghini S.p.A.

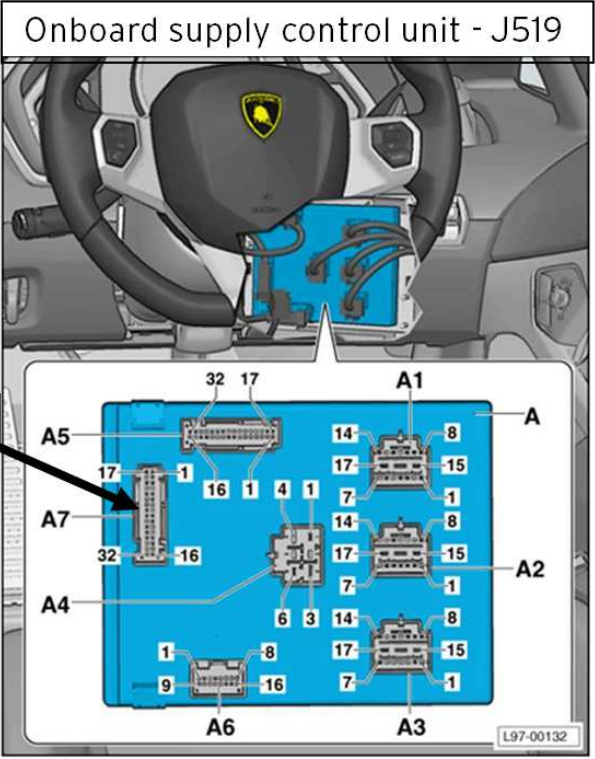

## Workshop instructions.

1	Disconnect the negative battery cable
	<p>Remove the lower side dashboard (<b>08 58 03</b>) cover to access the BCM1 and identify the 32 pin black connector A7 as shown in the picture</p> <p>Disconnect the black 32 pin connector from the BCM1 control unit – J519</p>
2	<p>A - Onboard supply control unit -J519.</p> <p>A1 - 17-pin connector, black (connector D) -T17dl.</p> <p>A2 - 17-pin connector, brown (connector E) -T17m.</p> <p>A3 - 17-pin connector, red (connector F) -T17n.</p> <p>A4 - 6-pin connector, black (connector G) -T6h.</p> <p>A5 - 32-pin connector, grey (connector A) -T32a.</p> <p>A6 - 16-pin connector, brown (connector C) -T16h.</p> <p>A7 - 32-pin connector, black (connector B) -T32b.</p>  <p>Onboard supply control unit - J519</p> <p>L97-00132</p>

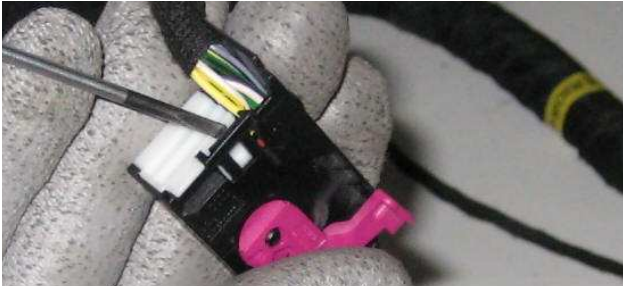
*The information and procedures published below are strictly confidential and intended exclusively for authorized operators and individuals. All copyrights are the property of Automobili Lamborghini S.p.A based on copyright law. The company reserves the right to make updates and modifications. The reprinting, reproduction, forwarding to unauthorized people and/or to third parties and partial or entire translation thereof are prohibited without written authorization from Automobili Lamborghini S.p.A.*

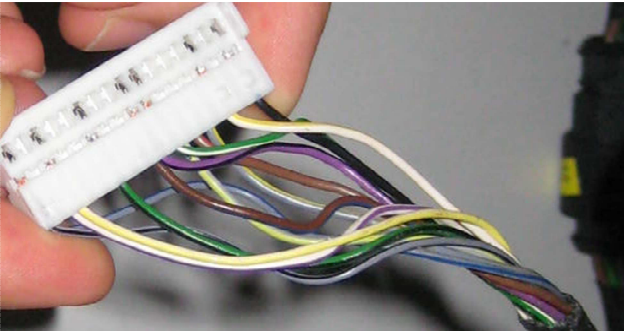

<p>3</p>	<p>Gently, unlock and remove the black plastic case from it, using a small screw driver or a secondary lock extractor.</p>	  
<p>4</p>	<p>Taking care to avoid any damage to the harness, cut the masking tape from the wire in order to free the wires for 10-12cm.</p>	 

*The information and procedures published below are strictly confidential and intended exclusively for authorized operators and individuals. All copyrights are the property of Automobili Lamborghini S.p.A based on copyright law. The company reserves the right to make updates and modifications. The reprinting, reproduction, forwarding to unauthorized people and/or to third parties and partial or entire translation thereof are prohibited without written authorization from Automobili Lamborghini S.p.A.*

5	Identify the pin locations in positions 14 and 19	
<p>Using a generic connector pin extractor, gently draw out the No.14 terminal (white/yellow wire) and No.19 terminal (white/purple wire) from the 32 pin black connector and <u>swap the two terminals</u>.</p> <p><b>STOP</b>  <b>Important!</b>  <b>Do not remove all terminals from the connector.</b></p>		
6		

The information and procedures published below are strictly confidential and intended exclusively for authorized operators and individuals. All copyrights are the property of Automobili Lamborghini S.p.A based on copyright law. The company reserves the right to make updates and modifications. The reprinting, reproduction, forwarding to unauthorized people and/or to third parties and partial or entire translation thereof are prohibited without written authorization from Automobili Lamborghini S.p.A.

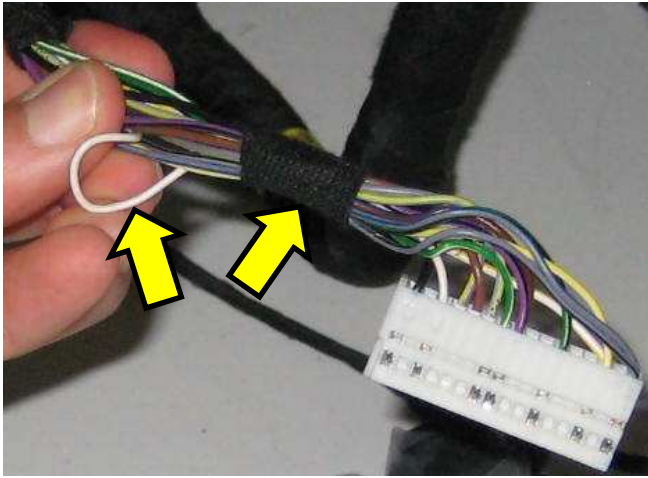
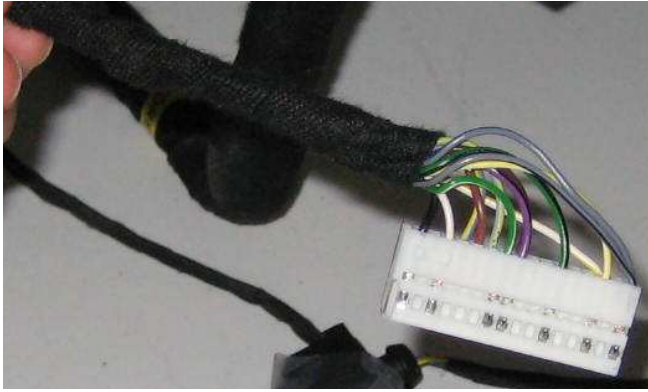

7	Bend the white-purple cable and fix it using masking tape, the as shown the picture.	
8	Cover all the harness with the masking tape.	
9	Put again the black plastic case on the 32 pin connector and fix it in the BCM1.	
10	Ensure that the connector is well fixed in its position.	
11	Reconnect the negative battery cable.	
12	Check that both left/right seat heaters fully operate well	
13	Do the electric windows learning procedure (104207).	

*The information and procedures published below are strictly confidential and intended exclusively for authorized operators and individuals. All copyrights are the property of Automobili Lamborghini S.p.A based on copyright law. The company reserves the right to make updates and modifications. The reprinting, reproduction, forwarding to unauthorized people and/or to third parties and partial or entire translation thereof are prohibited without written authorization from Automobili Lamborghini S.p.A.*



<b>14</b>	Set the clock time
<b>15</b>	Reinstall the passenger side dashboard cover in reverse order from the removal

Your Area Manager is at full disposal for further information.

Best regards

Customer Service

---

*The information and procedures published below are strictly confidential and intended exclusively for authorized operators and individuals. All copyrights are the property of Automobili Lamborghini S.p.A based on copyright law. The company reserves the right to make updates and modifications. The reprinting, reproduction, forwarding to unauthorized people and/or to third parties and partial or entire translation thereof are prohibited without written authorization from Automobili Lamborghini S.p.A.*